

P31 Series

Regenerative Turbine Pumps

Design Features

- Capacities to 5 GPM
- Heads to 250 Feet
- Temperatures to 250°F
- Stainless Steel Construction
- Compact Size
- Top Suction and Discharge
- Adjustable Casing for Extended Service Life and Expanded Performance Envelope
- Optional Integral Relief Valve



Diagram & Specs

- (1) Stainless Steel Casing
- (2) Optional Integral Relief Valve
- (3) Stainless Steel Motor Bracket
- (4) Corrosion Resistant Impeller
- (5) Self-centering Balanced Impeller
- (6) Long lasting Mechanical Seals
- (7) High Efficiency Water Channel Design
- (8) High-Temp "O" Rings
- (9) Casing Adjusting Ring

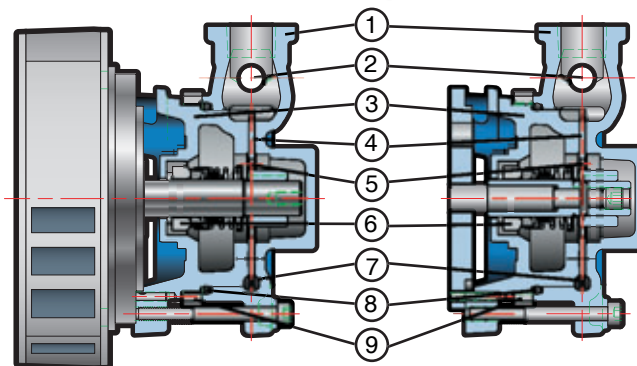

P31 on a Reversible 48 Frame Motor

P31 on a Compact 36 Frame Motor

Optional Features

Internal Flush Line

The P31 Series offers an optional internal seal flush to extend operating temperature to 250°F.

Integrated Relief Valve

P31 Pumps are available with or without a built-in relief valve*. The relief valve temporarily protects against dangerous over-pressure. All relief valves are preset at the factory to your specifications (60 to 100 psi range available). At the specified relief valve setting, the

flow will fully by-pass from the outlet to the inlet through the relief valve chamber. The specified relief valve setting is an average; individual pumps will vary both above and below the specified setting. The relief valve actually cracks open and begins to by-pass flow at approximately 50 psi below the relief valve setting. The standard relief valve is made of a special high temperature plastic.

Optional Motor Capabilities

All P31 pumps can fit onto ultra compact 36 Frame UL and CE approved motors, as well as Standard MTH dual face motors. Optional motors with higher horsepower, solid state starting, TEFC enclosures, and 3 phase capabilities are also available.

Construction Materials

PART	STANDARD CONSTRUCTION	OPTIONS
Motor Bracket and Casing	316 Stainless Steel (AISI 316)	---
Impeller	Bronze	W88 20% Nickel Silver (ASTM B584)
Seals and "O" Rings (All Elastomers)	Viton A	Buna EPR Neoprene
Seals	Carbon	G.L. Si Carbide G.L. Si Carbide
Seats	Ceramic	Silicon Carbide Ni-Resist
Shaft	304 Stainless Steel	---

Limitations

Casing Pressure (Max.)	300 PSI
Seal Pressure (Max.)*	200 PSI
Suction Pressure (Max.)	50 PSI
Suction Pressure (Min.)	26" Hg Vac.
Speed** (Max.)	5500 RPM

Temperature

Standard Construction	-20° F
Ceramic Seal Seat - Water	+230° F
G.I. Silicon Carbide Seal & Seat + Internal Seal Flush	+250° F

Horsepower

1 Phase	1/3 HP
3 Phase	1/3 HP

*Suction Pressure Plus 50 Percent of Differential Pressure

**With Variable Frequency Drive @90Hz

*Be advised that due to the design of the relief valve, the relief valve reacts to the difference in pressure between the inlet and the outlet. As a result, the highest pressure, which the pump can develop at its discharge port, is the inlet pressure plus the specified relief valve setting.

P31 Series

Performance Curves

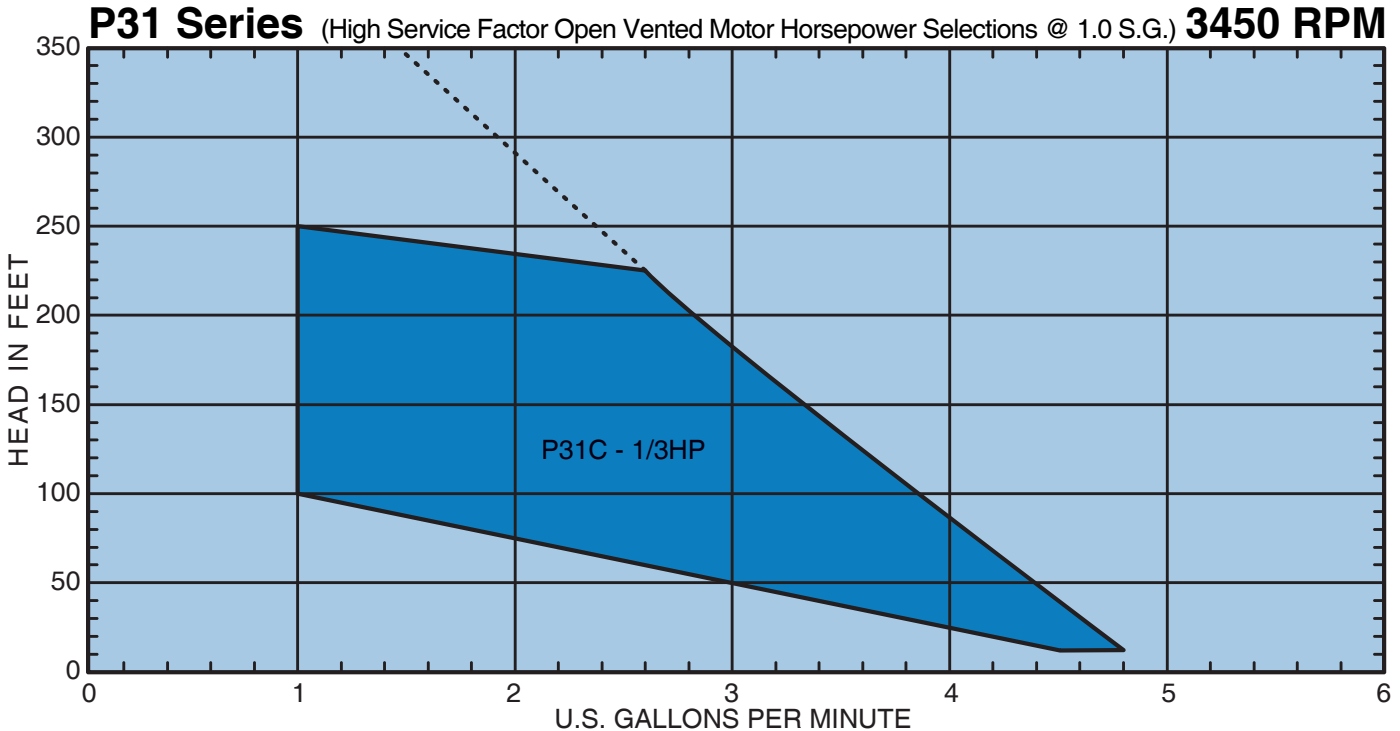

Engineering Specification

The contractor shall furnish (and install as shown on the plans) a P31 Series horizontal close coupled regenerative turbine type pump model _____ size 1/2" by 1/2" of 316 STAINLESS STEEL construction. Each pump shall have a capacity of _____ GPM when operating at a total head of _____ feet. Suction pressure will be _____ feet with a liquid temperature of _____ °F.

The pump is to be furnished with a mechanical seal with stainless steel metal parts, (Viton) (Buna) (EPR) elastomers and (Carbon/Ceramic Seal/Seat) (Graphite Impregnated Silicon Carbide Seal/Seat). The pump casing shall be vertically split, two piece design, top suction and top discharge rotated (0°) (90°) (180°) (270°) with water passageways in the cover and motor bracket. Impeller shall be made of (20% Nickel

Silver) (Bronze) (W88) material and be hydraulically self-centering. P31 Series pump will have an external casing adjustment feature that allows occasional renewal of performance by tightening internal clearances that have increased due to normal wear (and will have an integral relief valve suitable for limiting pressure production to a value of _____ psi.)

The pump shall be close-coupled to a _____ HP, _____ Phase _____ Hertz _____ Volt _____ RPM horizontal (open vent) (ODP) (TEFC) motor, with 304SS shaft, ball bearings, and UL and CE Marks. The motor shall be sized to prevent overloading at the highest head condition listed in this specification.

Dimensions

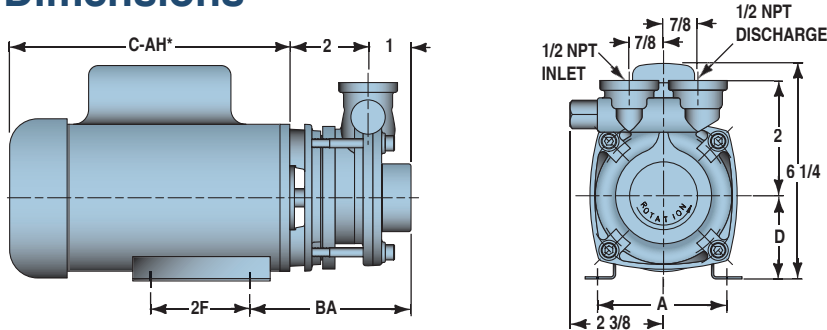

HP	Ph.	Encl.	Frame	Suction	Discharge	A	D	2F	BA	C-AH*
1/3	1	OPN	36	1/2"	1/2"	3	2.125	2.625	3.75	7.8
1/3	1	ODP	48	1/2"	1/2"	4.25	3	2.75	2.53	8.65

*Approximate maximum dimension

Notes:

A 20 mesh nominal strainer should be installed ahead of the pump suction to prevent foreign materials like pipe scale and rust from damaging the pump impeller and mechanical seal.

Motors have ball bearing construction and open ventilated enclosure. Motors are NOT drip-proof. Rated for continuous duty operation at all ratings shown.



MTH PUMPS

401 West Main Street • Plano, IL 60545-1436
 Phone: 630-552-4115 • Fax: 630-552-3688
 Email: SALES@MTHPUMPS.COM
 http://WWW.MTHPUMPS.COM