

D51DM SERIES

Pump Manual

VERTICAL CLOSE COUPLED

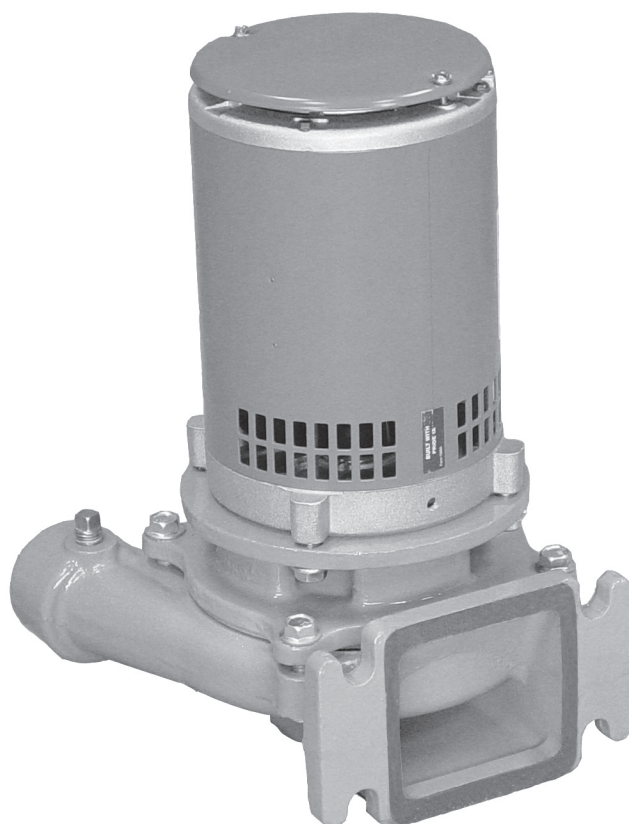

MTH PUMPS

401 West Main Street • Plano, IL 60545-1436
Phone: 630-552-4115 • Fax: 630-552-3688
Email: SALES@MTHPUMPS.COM
<http://WWW.MTHPUMPS.COM>

SUCTION PIPING

The D51CM generally bolts directly to a tank so there is no suction piping. Occasionally an isolation valve may be included ahead of the pump suction. There are many different types of suction valves. Some are machined casings which bolt directly to the tank and the pump bolts directly to the valve. There are also types of valves which are gate valves with piping attached. If a fabricated valve is used, make sure the piping is at least 2" or a reduction in pump GPM may occur.

CAUTION -Never use the suction isolation valve to throttle the pump.

DISCHARGE PIPING

Always use pipe that is the same size or one size larger than the discharge size of the pump. If you use pipe smaller than the 1 1/4" NPT discharge on the D51CM, the pumping capacity will be diminished. We recommend a section of pipe 12 1/2 inches long as the lead pipe out of the pump discharge. A check valve, gate valve and a union should also be installed in the discharge line for pump throttling and servicing. See Typical Piping Diagram. Make sure the discharge line is well supported. NEVER use the pump as pipe support.

ELECTRICAL CONSIDERATIONS

Electrical supply must be a separate branch circuit with fuses or circuit breakers. Install a disconnect switch as close to the pump as possible. Wire in accordance with the National Electric Code and local codes where applicable.

CAUTION -Always disconnect electrical power when handling the pump or controls.

Motors must be wired for proper voltage. Motor wiring diagram is on the motor nameplate. Single-phase motors are usually furnished as dual voltage 115/230/1/60. Three phase motors are usually furnished as tri voltage 208/230/460/3/60. All three phase motors require a magnetic motor starter and thermal overload protection. Single-phase motors up to and including 1 horsepower have built in thermal protection. Check motor nameplate to confirm overload protection is built in. All single-phase motors above 1 HP require magnetic starters and thermal overload protectors. Always limit your wire size so the maximum voltage is no more than 10% of motor nameplate voltage at the motor leads. If this voltage drop is exceeded, motor and pump life will be greatly diminished.

MOTOR ROTATION

The correct motor rotation (when viewed from the motor end of the pump) is clockwise. Pop cap off the back of the motor; the motor shaft is now exposed for viewing. Switch the power on and off quickly and observe the motor shaft. If the rotation is counterclockwise change any two motor leads on a three-phase motor. Single-phase motors are nonreversible.

PUMP STARTUP

Make sure the suction gate valve is wide open; when the pump is in operation this valve should never be throttled. Open the discharge gate valve about 1/4 open. This will prime the pump and force air out. **NEVER** run the pump dry. Rotating parts will eventually seize and mechanical seal damage may occur. **NEVER** run the pump at shutoff conditions. Energy from the motor is imparted to the liquid which is converted to heat. The liquid may flash to vapor causing the pump to burst.

Once the pump is started and running adjust the discharge gate valve to your desired pressure. Make sure there are no leaks in pump connections and piping. Check your motor amps to make sure the motor is running within its rated capacity. The pump should be running smooth with no vibration or excessive noise.

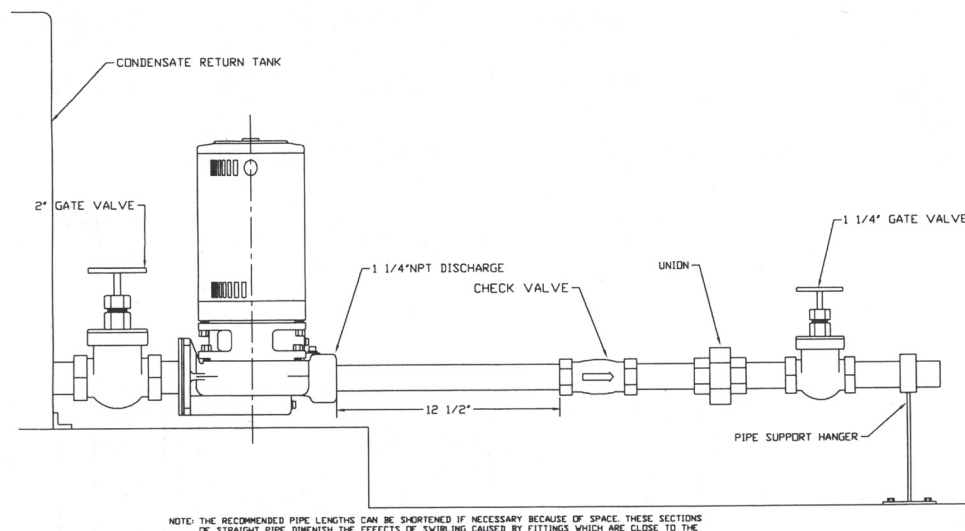

Figure 1-1

MAINTENANCE

The bearings in the close-coupled motor are sealed and permanently greased. No other greasing is required. Periodic 6-month checks of the unit should be made to make sure the unit runs smoothly at its desired performance. If possible keep a log of the suction pressure, discharge pressure and motor amps. Over a period of time this information can tell you if the pump parts are starting to wear. If a problem arises check the troubleshooting section for guidance. If the problem cannot be rectified call your local distributor or the factory.

PUMP DISASSEMBLY

1. Shut disconnect off. Always make sure the power to the pump is off.
2. Close suction and discharge gate valves.
3. Drain the pump by removing the top and bottom 1/8 NPT plugs on the casing
4. Loosen and remove the compression fitting on the adapter, pull the copper tubing free and move out of your way.
5. Remove the motor hold down bolts.
6. Remove the four bolts that hold the adapter to the casing.
7. Slide back pull out assembly out of casing, it may be necessary to pry them apart.
8. Remove the casing o-ring and set it aside. Inspect it to make sure it's not cut. Clean the o-ring groove on the casing.
9. Remove the impeller cap screw.
10. The back of the motor will have a small cap on it, pry it off. This reveals the end of the motor shaft which has a screwdriver slot or flats on it.
11. Remove the impeller. Use a screwdriver or a wrench to hold the

exposed motor shaft. Carefully grab the impeller (be careful not to cut yourself on any sharp edges) and turn it counterclockwise. It may be very hard to get the impeller free.

12. Remove the mechanical seal rotating elements.

13. Remove the four bolts holding the adapter to the motor. The adapter,

which still has the stationary members of the seal in it, will now pull off the motor.

14. Remove the stationary member of the seal and clean all the parts. Be very careful not to scratch the seal face, this will cause the seal to leak.

15. To reassemble follow the directions in reverse.

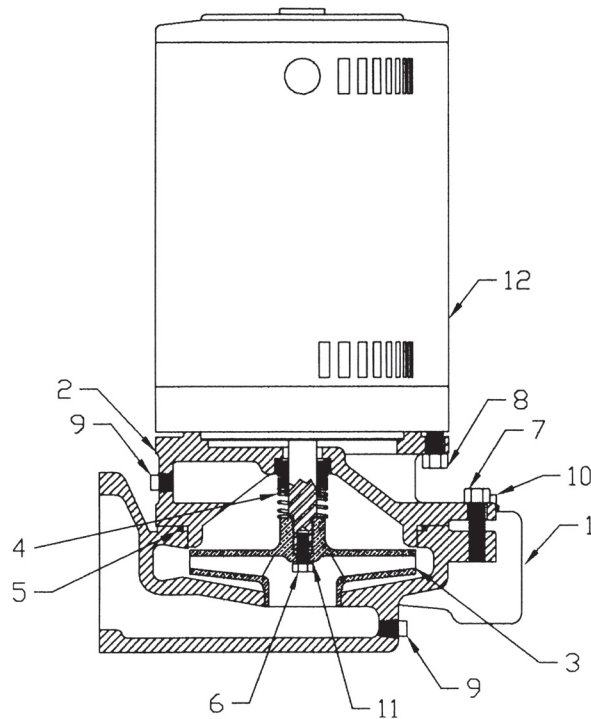

D51DM Bronze Fitted

1	Casing VA512	Class 30 Cast Iron	40026	1
2	Adapter A510	Class 30 Cast Iron	30000	1
3	Impeller A510	Bronze	20000	1
4	Mechanical Seal	Buna-N	S-100	1
		EPT	S-101	
		Viton	S-102	
5	O-ring Casing	Buna-N	S-109	1
		EPT	S-110	
		Viton	S-111	
6	Cap Screw	1/4-28UNF X 5/8 SS	70040	1
7	Cap Screw	3/8-16 X 1 1/4 Steel	19932	4
8	Cap Screw	3/8-16 X 1 Steel	19932	4
9	Pipe Plug	1/8 NPT Bronze	69845	5
10	Pipe Plug	1/4 NPT Bronze	68585	2
11	Lockwasher	1/4 303 SS	0130197	1
12	Motor	Nema 56J	---	1

TROUBLESHOOTING

A.) PUMP WILL NOT RUN

- 1.) Circuit breaker is open
- 2.) Thermal overload has tripped
- 3.) Improper voltage supplied to the motor
- 4.) Wiring connections are loose
- 5.) Blown fuse
- 6.) Pump controls in off position
- 7.) Motor wired improperly
- 8.) Motor is defective

B.) GPM CAPACITY IS LOW

- 1.) Pump is not throttled correctly
- 2.) Pump is running backwards
- 3.) Pump has lost its prime
- 4.) The impeller was sized wrong -the diameter is too small
- 5.) Impeller is worn -clearance opened up
- 6.) Air or gas in the liquid 7.) NPSHA is to low
- 8.) Piping is undersized
- 9.) The impeller has a vane or vanes plugged with debris
- 10.) A strainer is partially plugged
- 11.) Pump is undersized for the system
- 12.) Phase loss -one leg of a 3-phase motor went out

C.) EXCESSIVE NOISE/VIBRATION

- 1.) Rotating parts are binding
- 2.) Pump is cavitating
- 3.) Defective motor
- 4.) Pump is running backwards
- 5.) Air or gas in system
- 6.) Impeller is plugged with debris
- 7.) Pump or piping is loose
- 8.) Pump is not throttled correctly - running wide open



MTH PUMPS

401 West Main Street • Plano, IL 60545-1436
Phone: 630-552-4115 • Fax: 630-552-3688
Email: SALES@MTHPUMPS.COM
<http://WWW.MTHPUMPS.COM>